

**REFERENCES:**

ALL BOUNDARY & TOPOGRAHY INFORMATION IS REFERENCED FROM A SURVEY PREPARED BY SCALICE SURVING, DATED APRIL 26, 2021, PROVIDED BY OWNER.

**NOTES:**

1. ALL DIMENSIONS SHALL BE TO FACE UNLESS OTHERWISE NOTED.
2. THE CONTRACTOR SHALL BE RESPONSIBLE FOR OBTAINING ALL NECESSARY PERMITS AND APPROVALS FROM THE APPLICABLE AGENCIES.
3. THE CONTRACTOR SHALL MAINTAIN ACCESS TO ALL ADJACENT PROPERTIES AT ALL TIMES.
4. ALL WORK SHALL BE COMPLETED WITHIN THE SPECIFIED TIME FRAME.
5. THE CONTRACTOR SHALL BE RESPONSIBLE FOR THE PROTECTION AND PRESERVATION OF ALL EXISTING UTILITIES AND STRUCTURES.
6. ALL MATERIALS AND METHODS OF CONSTRUCTION SHALL BE APPROVED BY THE ENGINEER.
7. THE CONTRACTOR SHALL MAINTAIN RECORDS OF ALL WORK AND MATERIALS USED.
8. THE CONTRACTOR SHALL BE RESPONSIBLE FOR THE DISPOSAL OF ALL DEBRIS AND WASTE.
9. THE CONTRACTOR SHALL BE RESPONSIBLE FOR THE PROTECTION OF THE ENVIRONMENT.
10. ALL WORK SHALL BE COMPLETED IN ACCORDANCE WITH ALL APPLICABLE CODES AND REGULATIONS.

**BULK REQUIREMENTS**

ITEM	REQUIREMENT	NOTES
1	MINIMUM LOT AREA (SQ. FEET)	10,000
2	MINIMUM LOT WIDTH (FEET)	50
3	MINIMUM FRONT YARD SETBACK (FEET)	20
4	MINIMUM SIDE YARD SETBACK (FEET)	5
5	MINIMUM REAR YARD SETBACK (FEET)	5
6	MAXIMUM GROUND COVER (PERCENT)	40
7	MINIMUM OPEN SPACE (PERCENT)	10
8	MINIMUM NUMBER OF TREES (DIAMETER AT BREAST HEIGHT 4" OR GREATER)	2
9	MINIMUM NUMBER OF TREES (DIAMETER AT BREAST HEIGHT 2" OR GREATER)	5

**ZONE: R-40**

ITEM	REQUIREMENT	NOTES
1	MINIMUM LOT AREA (SQ. FEET)	10,000
2	MINIMUM LOT WIDTH (FEET)	50
3	MINIMUM FRONT YARD SETBACK (FEET)	20
4	MINIMUM SIDE YARD SETBACK (FEET)	5
5	MINIMUM REAR YARD SETBACK (FEET)	5
6	MAXIMUM GROUND COVER (PERCENT)	40
7	MINIMUM OPEN SPACE (PERCENT)	10
8	MINIMUM NUMBER OF TREES (DIAMETER AT BREAST HEIGHT 4" OR GREATER)	2
9	MINIMUM NUMBER OF TREES (DIAMETER AT BREAST HEIGHT 2" OR GREATER)	5

**AREA CALCULATIONS - FOOTPRINT**

STRUCTURE	FOOTPRINT AREA (SQ. FT.)	TOTAL
Primary Structure	1,000	2,184
Accessory Structures	1,184	3,368
Pool	170	3,538
Impervious Surfaces	4,480	8,018
Other	428	8,446

**BUILDING REQUIREMENTS**

ITEM	REQUIREMENT	NOTES
1	MINIMUM CEILING HEIGHT (FEET)	7
2	MINIMUM FLOOR AREA (SQ. FEET)	100
3	MINIMUM WINDOW AREA (SQ. FEET)	10
4	MINIMUM DOOR AREA (SQ. FEET)	10
5	MINIMUM STAIR WIDTH (FEET)	3
6	MINIMUM STAIR RISE (INCHES)	7
7	MINIMUM STAIR RUN (INCHES)	11
8	MINIMUM STAIR HEADROOM (FEET)	6
9	MINIMUM STAIR TREAD (INCHES)	11

**POOL CALCULATION REQUIRED TO CR**

ITEM	REQUIREMENT	NOTES
1	MINIMUM POOL AREA (SQ. FEET)	100
2	MINIMUM POOL DEPTH (FEET)	3
3	MINIMUM POOL VOLUME (CU. FEET)	10,000
4	MINIMUM POOL SURFACE AREA (SQ. FEET)	100



LOCATION MAP  
NTS

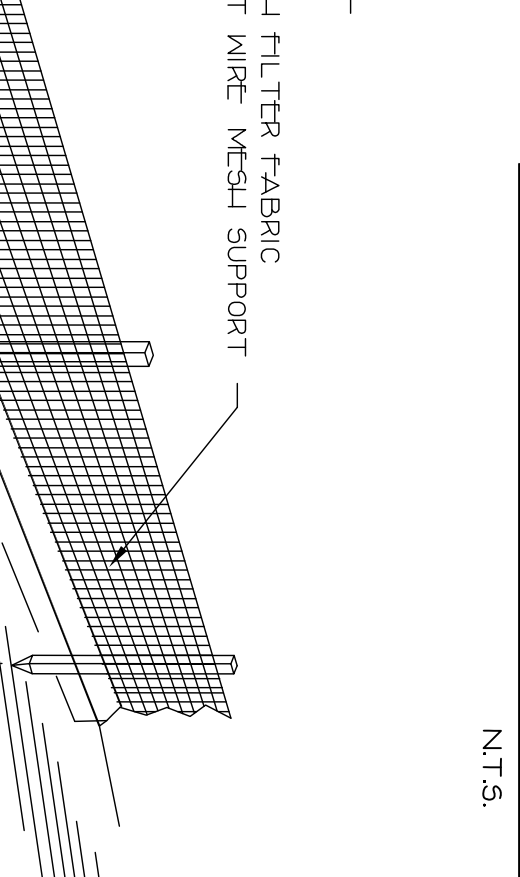
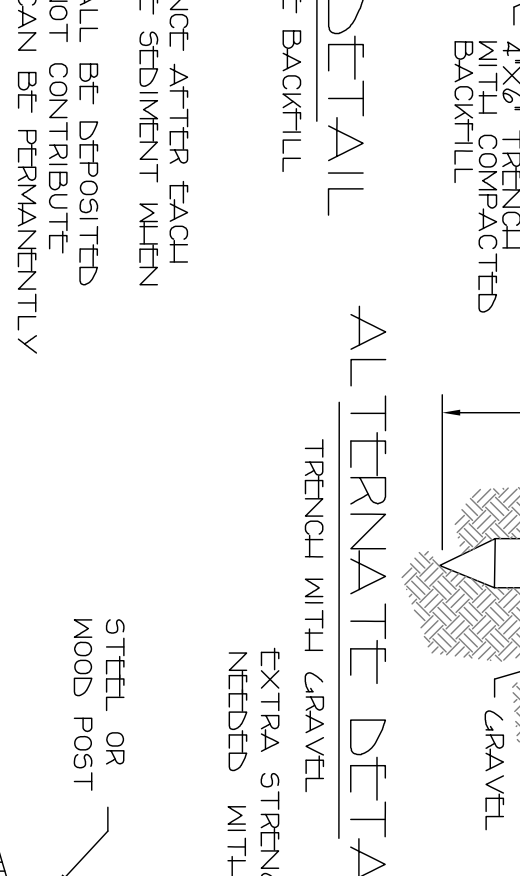
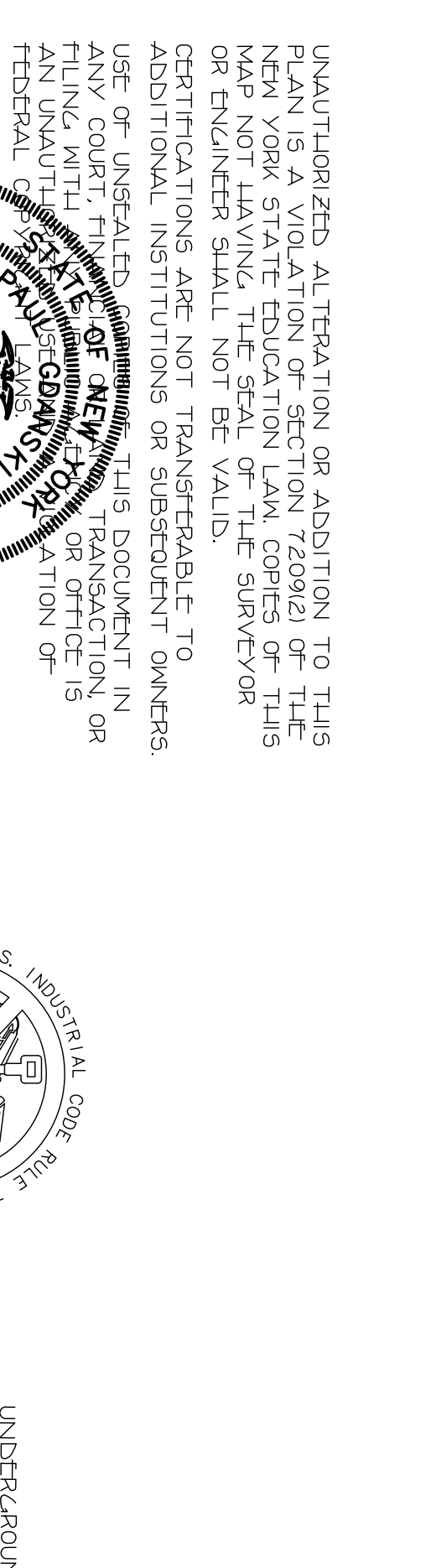
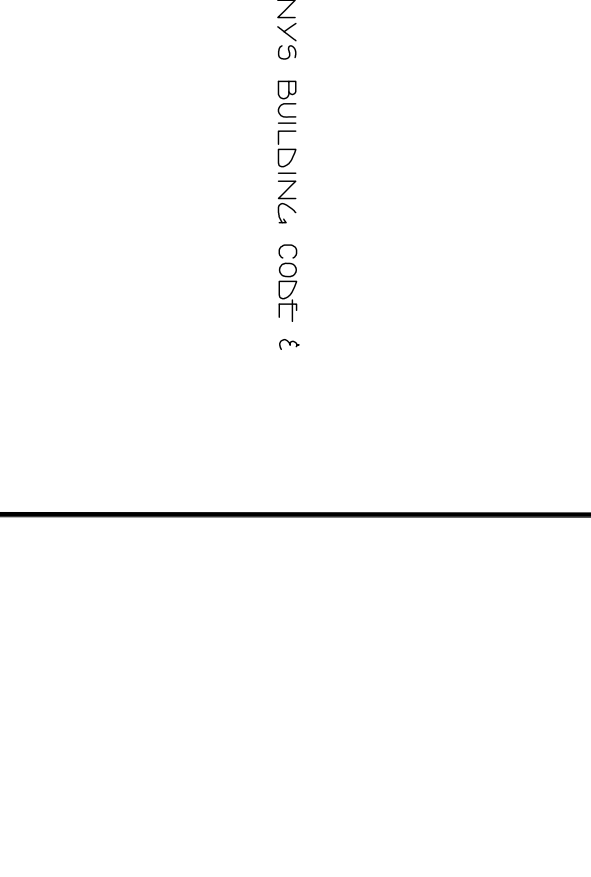
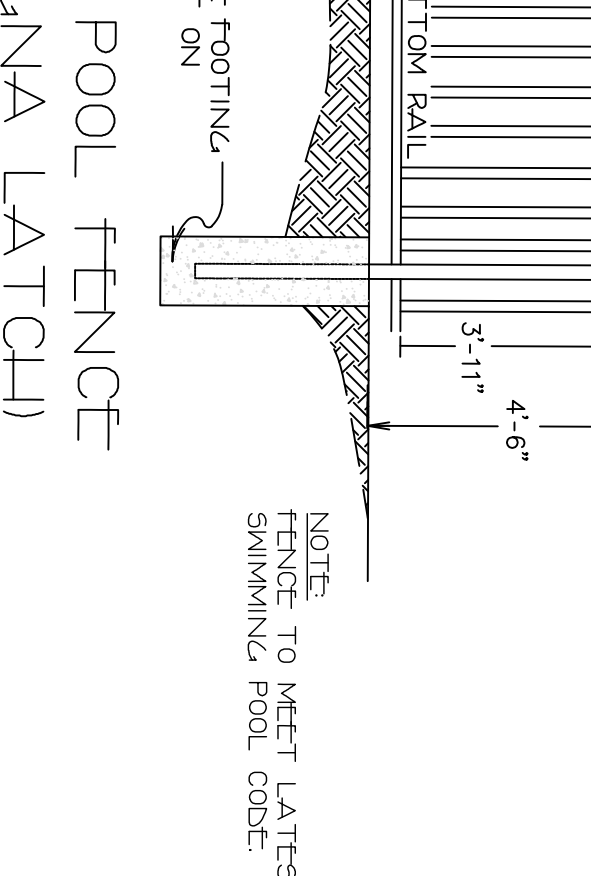
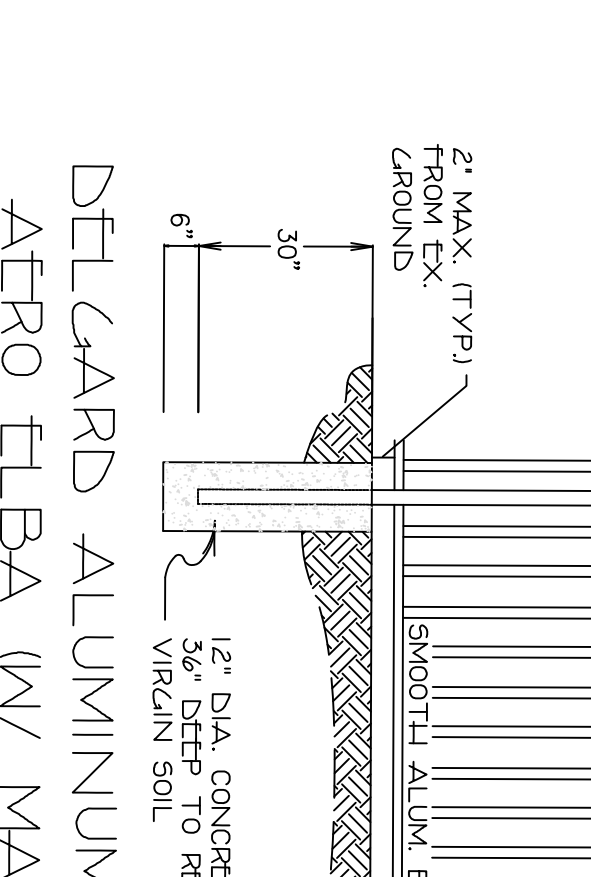
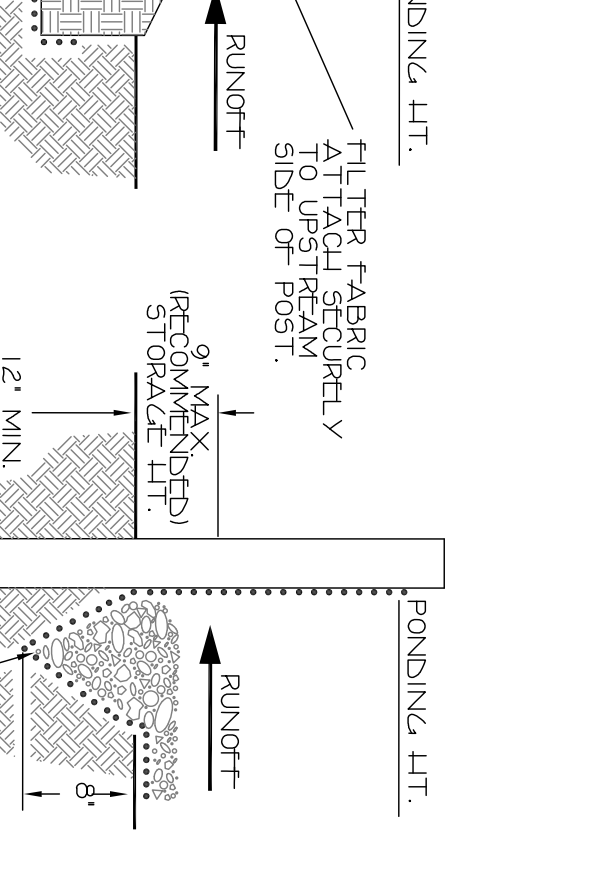
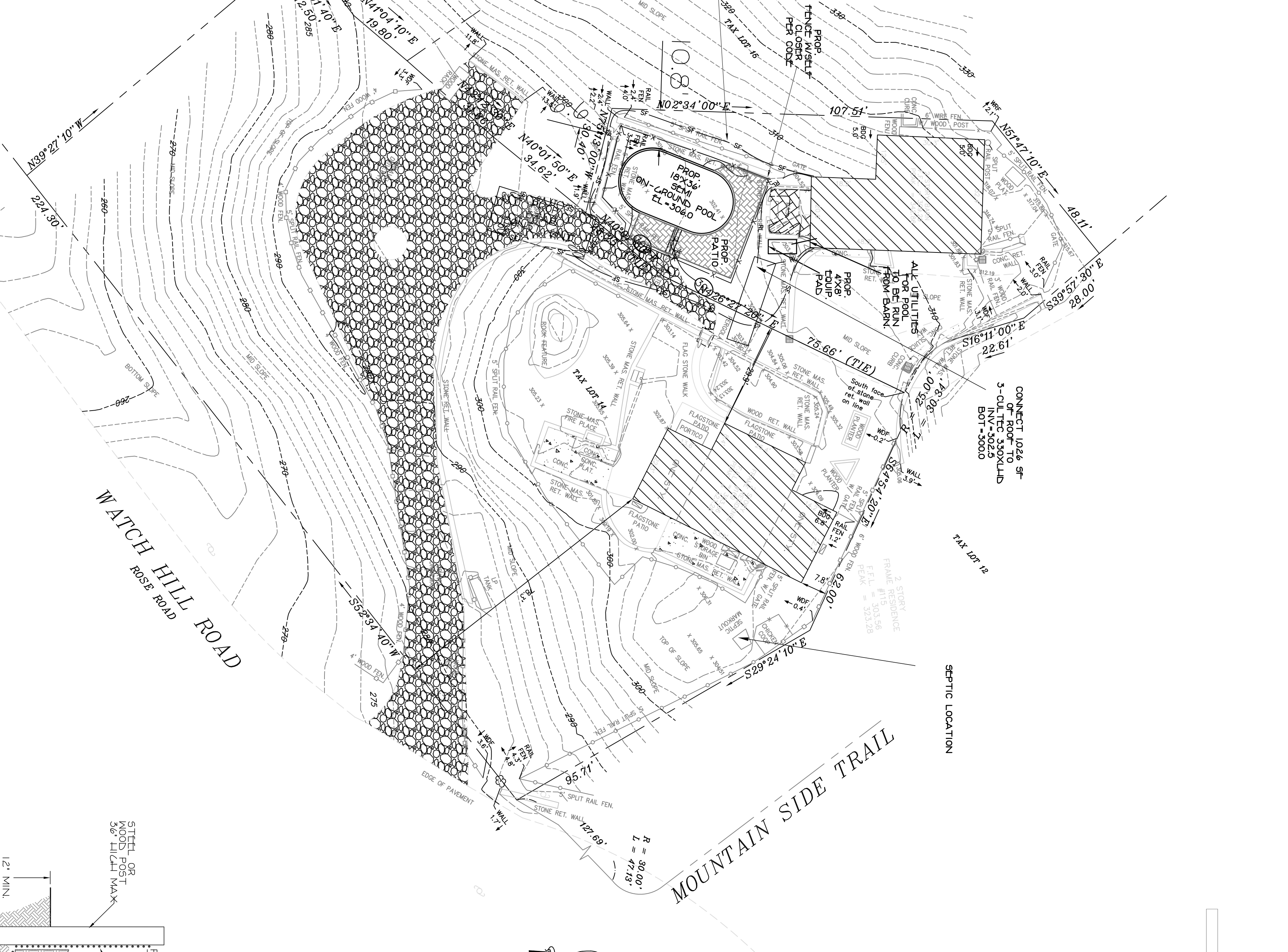
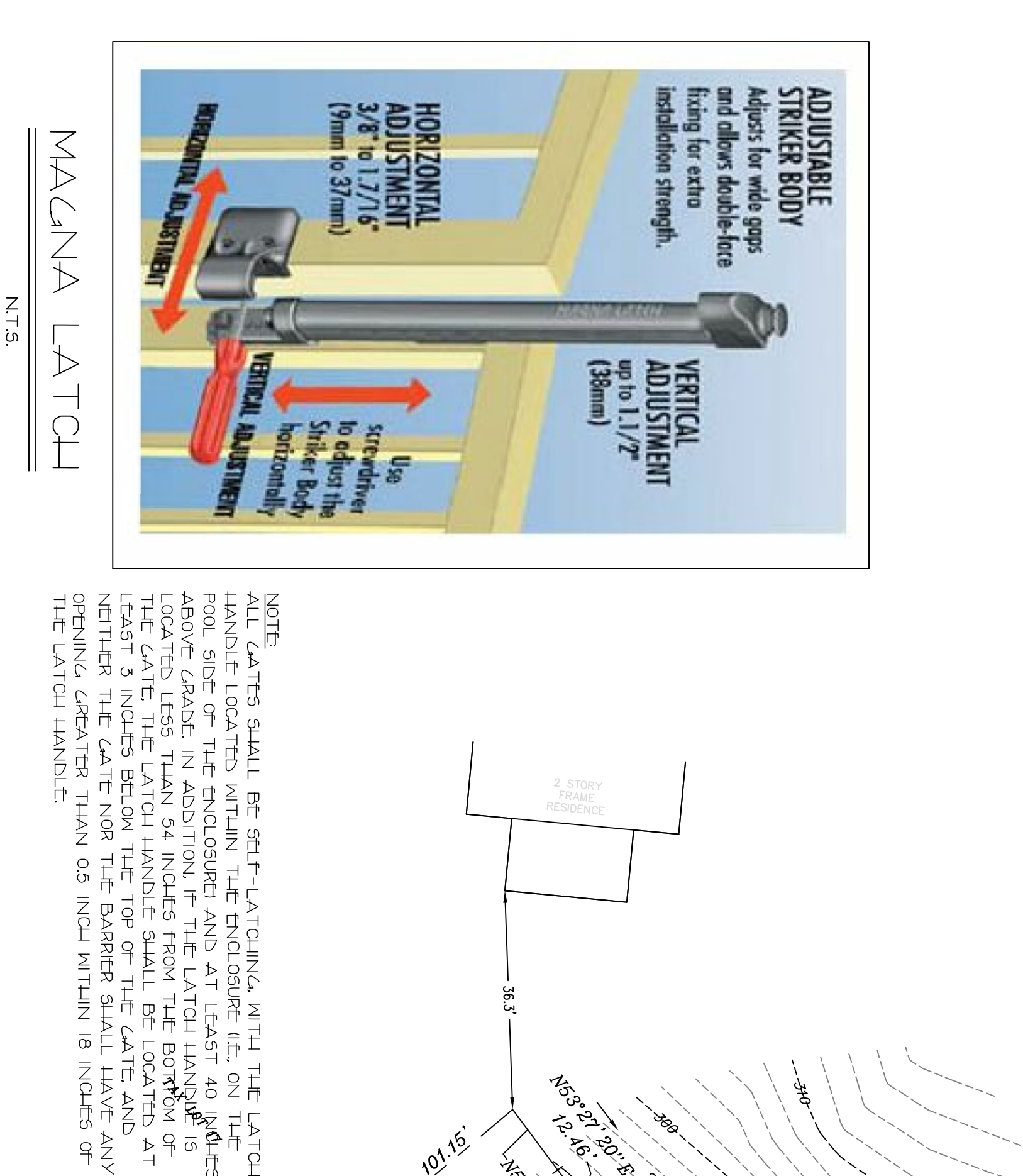
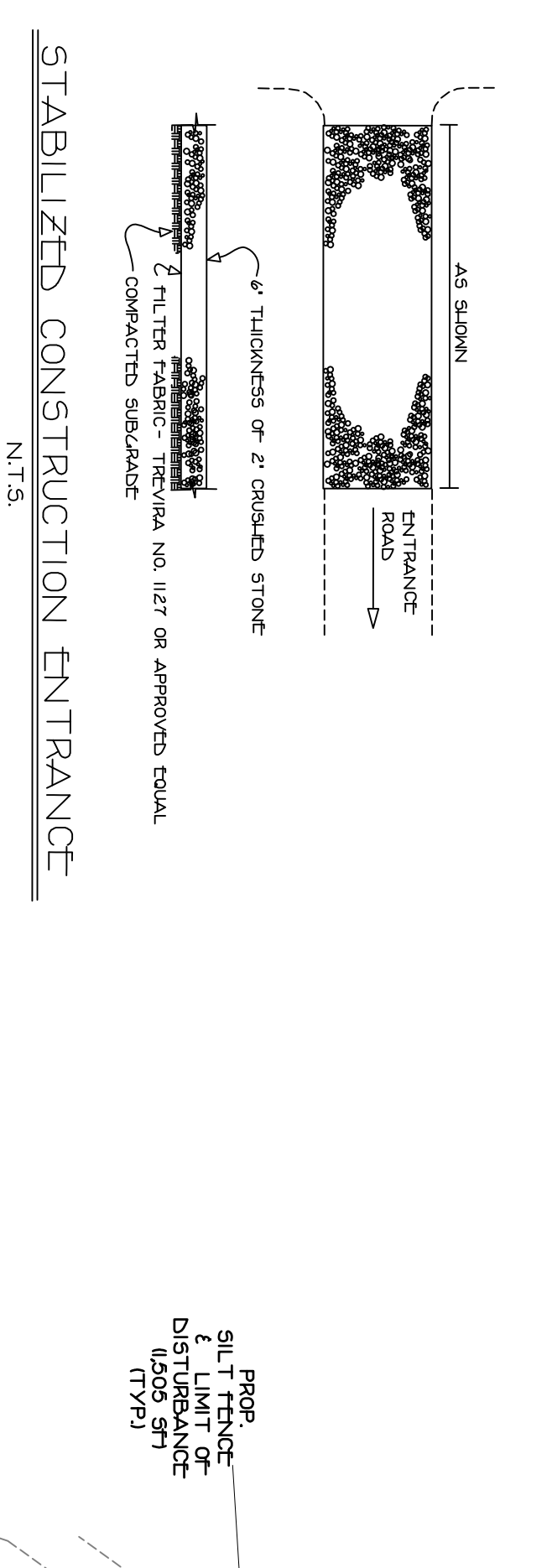
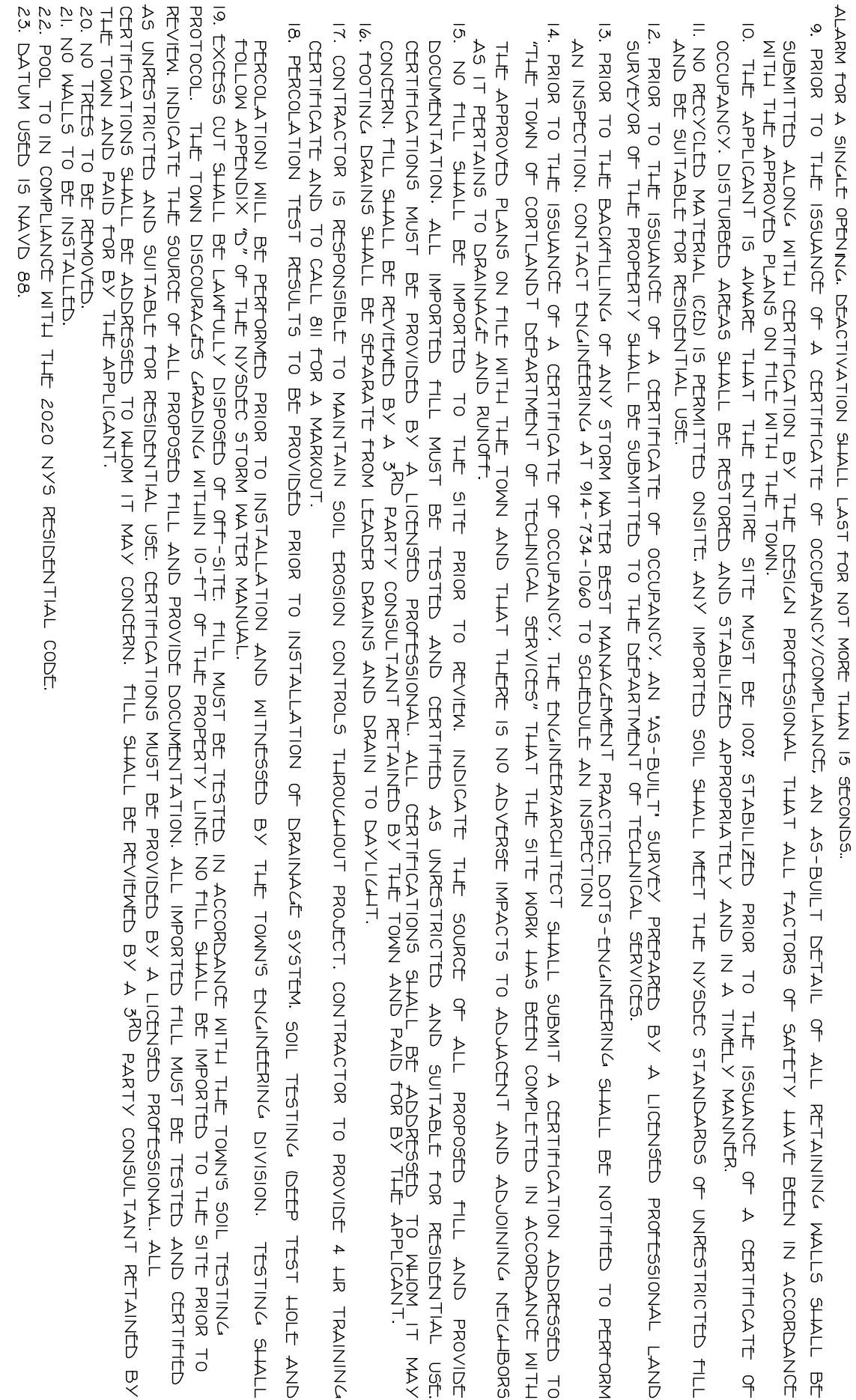

SITUATE IN THE TOWN OF CORTLANDT WESTCHESTER COUNTY, NEW YORK  
TAX LOT 4419-1-14  
169 WATCH HILL ROAD  
FOR COLUCCI  
PAUL GDANSKI P.E., PLLC  
633 WOODMONT LANE  
SLAATSBURG, NEW YORK 10974  
EMAIL: P.G.DANSKI@EARTHLINK.NET

**PAUL GDANSKI P.E., PLLC**  
LICENSED PROFESSIONAL ENGINEER  
STATE OF NEW YORK  
EXPIRES 12/31/2024

UNDERSTANDS UTILITIES ARE SHOWN IN AN APPROXIMATE WAY FROM AVAILABLE INFORMATION. THE CONTRACTOR SHALL CALL THE LOCAL UTILITIES TO LOCATE AND MARK ALL UTILITIES PRIOR TO ANY CONSTRUCTION. THE CONTRACTOR SHALL ALSO VERIFY THE LOCATION, SIZE AND DEPTH OF ALL UTILITIES PRIOR TO ANY CONSTRUCTION. ANY UTILITIES FOR WHICH EVIDENCE CAN BE SEEN ON THE SURFACE OF THE LANDS MAY NOT BE SHOWN ON THIS DRAWING.

**PAUL GDANSKI P.E., PLLC**  
LICENSED PROFESSIONAL ENGINEER  
STATE OF NEW YORK  
EXPIRES 12/31/2024

SCALE: 1" = 20'

DATE: 5/17/21