

# CVE - CORTLANDT (LEXINGTON)

TOWN OF CORTLANDT  
WESTCHESTER COUNTY, NEW YORK

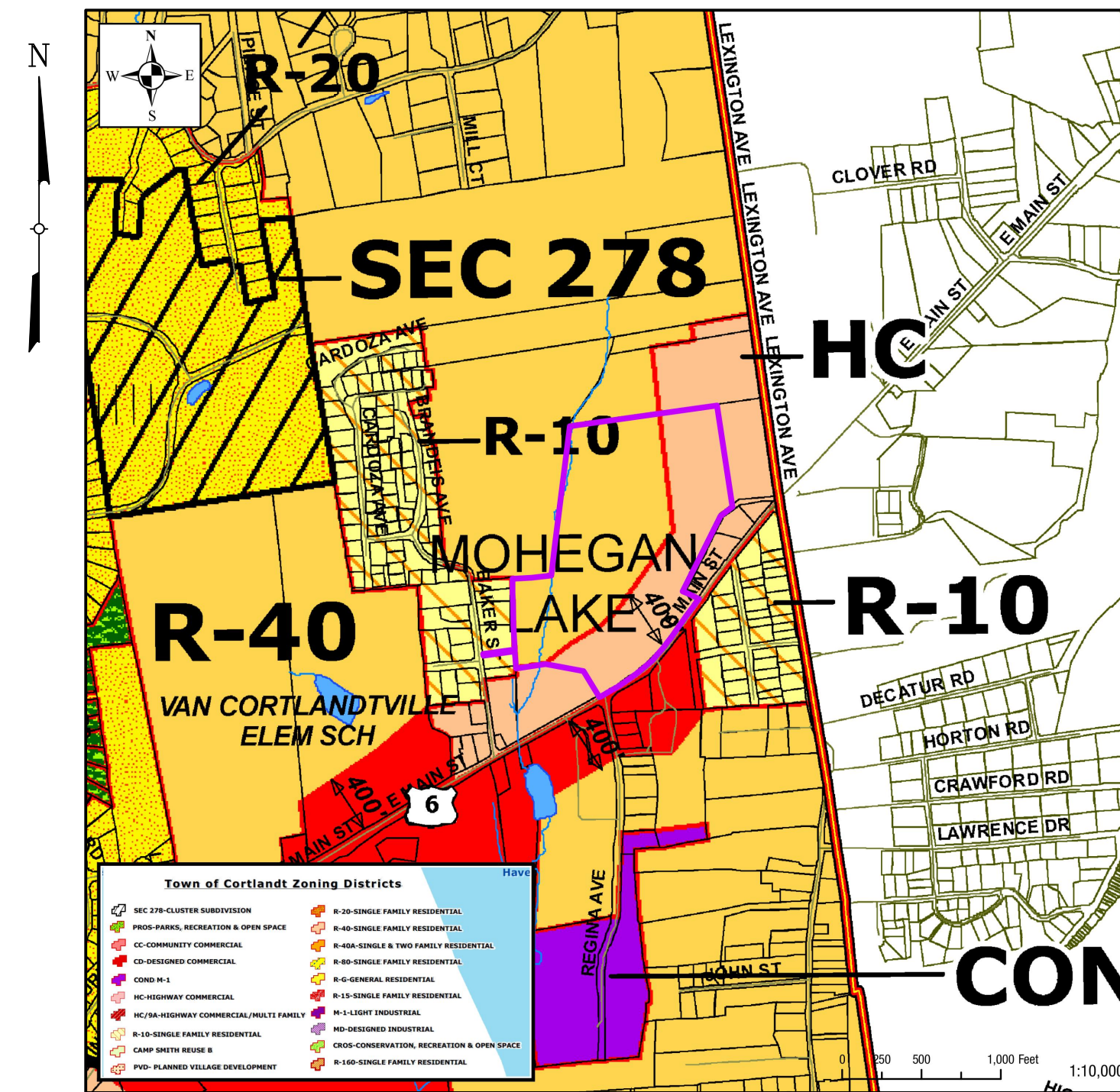

## LIST OF DRAWINGS

SK-100	COVER SHEET
SK-101	ADJOINERS LIST, ZONING TABLE, LEGEND & NOTES
SK-102	ADVANCED CONCEPT PLAN
SK-103	SLOPE MAP
SK-104	SLOPE MAP



## PROJECT DESIGN

TECTONIC ENGINEERING & SURVEYING CONSULTANTS P.C.  
70 PLEASANT HILL ROAD  
MOUNTAINVILLE, NY 10953  
(845) 534-5959

## APPLICANT

CVE GROUP.  
109 W 27TH ST., 8TH FLOOR  
NEW YORK, NY 10001

ALEXANDER V. FOX  
(866) 214-2947

## APPLICANT'S REPRESENTATIVE

ANNE E. KLINE, ESQ  
DEBELLO, DONNELLAN, WEINGARTEN, WISE &  
WIEDERKEHR, LLP  
ONE NORTH LEXINGTON AVENUE, 11TH FLOOR  
WHITE PLAINS, NEW YORK 10601  
(914) 681-0200

## OWNER

HYMAN MENDOLOWITZ, ET AL  
13 WINTERBERRY COURT  
PEEKSKILL, NY 10566

UNAUTHORIZED ALTERATION OR ADDITIONS TO A DOCUMENT BEARING THE SEAL OF A LICENSED PROFESSIONAL ENGINEER OR LAND SURVEYOR IS A VIOLATION OF SECTION 7209 SUBSECTION 2 OF THE NEW YORK STATE EDUCATION LAW.

COPIES OF THIS DOCUMENT WITHOUT A FACSIMILE OF THE SIGNATURE AND AN ORIGINAL EMBOSSSED SEAL OR ORIGINAL STAMP OF THE PROFESSIONAL ENGINEER OR LAND SURVEYOR SHALL NOT BE CONSIDERED VALID COPIES.

THIS DOCUMENT IS PREPARED SPECIFICALLY FOR THE CLIENT AND PROJECT DESIGNATED HEREON. MODIFICATION, ALTERATION, REVISION, DUPLICATION, OR USE WITHOUT THE CONSENT OF TECTONIC IS STRICTLY PROHIBITED. COPYRIGHT 2019 TECTONIC. ALL RIGHTS RESERVED.



Rev	Date	Revision	Approved	DRAWING CONTROL			
1	5/29/19	UPDATE RACKING SYSTEM PER CLIENT		Designed by: AMS	Drawn by: EDM	Checked by: LJG	
2	7/10/19	ADDED SCREENING AND EQUIPMENT		Purpose	Released by	Date	
				<input type="radio"/> For Comment			
				<input type="radio"/> For Approval			
				<input type="radio"/> For Bid			
				<input type="radio"/> For Construction			

**Tectonic**  
PRACTICAL SOLUTIONS. EXCEPTIONAL SERVICE.  
Tectonic Engineering & Surveying Consultants P.C.  
70 Pleasant Hill Road Phone: (845) 534-5959  
P.O. Box 37 (800) 829-6531  
Mountainville, NY 10953  
www.tectonicengineering.com

## COVER SHEET

CVE - CORTLANDT (LEXINGTON)  
3262 E. MAIN STREET  
TOWN OF CORTLANDT  
WESTCHESTER COUNTY, NEW YORK

Date: 5/9/2019	Work Order	Drawing No.	Rev
Scale: AS NOTED	9489.01	SK-100	2



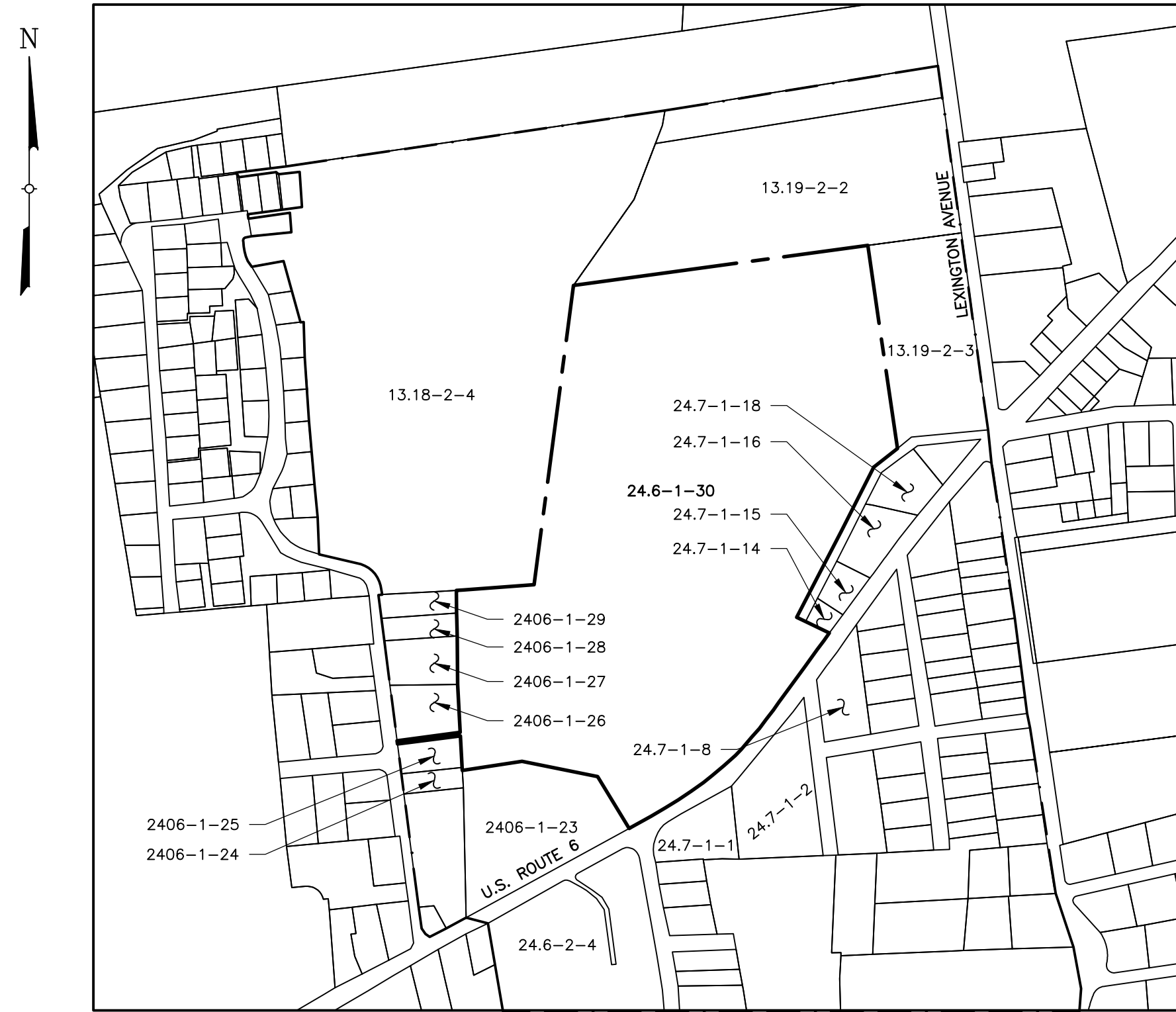

**ADJOINER MAP**  
SCALE: NTS

**LIST OF PROPERTY OWNERS**

<b>SECTION 13.18, BLOCK 2, LOT 4</b> CORTLANDT COLONY INC BRANDEIS AVE CORTLANDT MANOR, NY 10567	<b>SECTION 24.6, BLOCK 1, LOT 29</b> O'SHA, GERALD 44 BAKER ST CORTLANDT MANOR, NY 10567
<b>SECTION 13.19, BLOCK 2, LOT 2</b> KB OREO LIMITED LIABILITY COMPANY 3451 LEXINGTON AVE CORTLANDT MANOR, NY 10567	<b>SECTION 24.6, BLOCK 1, LOT 30 (SUBJECT PARCEL)</b> HYMAN MENDELOWITZ, ET AL 12 WINTERBERRY CT PEEKSKILL, NY 10566
<b>SECTION 13.19, BLOCK 2, LOT 3</b> MOHEGAN GROUP LIMITED LIABILITY COMPANY 3441 LEXINGTON AVE CORTLANDT MANOR, NY 10567	<b>SECTION 24.6, BLOCK 2, LOT 4</b> RYAN MAIN LIMITED LIABILITY COMPANY 111 BROOK ST SCARSDALE, NY 10583
<b>SECTION 24.6, BLOCK 1, LOT 23</b> SCHWARTZ, V LIMITED LIABILITY COMPANY 3200 E MAIN ST CORTLANDT MANOR, NY 10567	<b>SECTION 24.7, BLOCK 1, LOT 1</b> SKYVIEW/WESTVIEW LIMITED LIABILITY COMPANY PO BOX 453 SHRUB OAK, NY 10588
<b>SECTION 24.6, BLOCK 1, LOT 24</b> LAUGHLIN, JANICE E. 20 BAKER ST CORTLANDT MANOR, NY 10567	<b>SECTION 24.7, BLOCK 1, LOT 2</b> SKYVIEW/WESTVIEW LIMITED LIABILITY COMPANY PO BOX 453 SHRUB OAK, NY 10588
<b>SECTION 24.6, BLOCK 1, LOT 25</b> LAUGHLIN, AMBER M. 24 BAKER ST CORTLANDT MANOR, NY 10567	<b>SECTION 24.7, BLOCK 1, LOT 8</b> FERRARI, CARL & GABRIELLE 18 HELENA AVE MOHEGAN LAKE, NY 10547
<b>SECTION 24.6, BLOCK 1, LOT 26</b> LAUGHLIN, WILLIAM C. 30 BAKER ST CORTLANDT MANOR, NY 10567	<b>SECTION 24.7, BLOCK 1, LOT 14</b> RICOCHETE REALTY 529 ROCKLAND AVE MAMARONECK, NY 10543
<b>SECTION 24.6, BLOCK 1, LOT 27</b> LAUGHLIN, JOHN & WENDA 38 BAKER ST CORTLANDT MANOR, NY 10567	<b>SECTION 24.7, BLOCK 1, LOT 15</b> BOOT HILL CO, INC. PO BOX 964 MOHEGAN LAKE, NY 10547
<b>SECTION 24.6, BLOCK 1, LOT 28</b> VIZE, JOHN P. & LAURIE A. 42 BAKER ST CORTLANDT MANOR, NY 10567	<b>SECTION 24.7, BLOCK 1, LOT 16</b> RUGGED BOOT INC PO BOX 562 MOHEGAN LAKE, NY 10547
	<b>SECTION 24.7, BLOCK 1, LOT 18</b> C.M.N. HOLDING INC. 3262 E MAIN ST MOHEGAN LAKE, NY 10547

**ZONING TABLE**

TOWN OF CORTLANDT - ZONING DISTRICTS R-40 SINGLE FAMILY AND HC - HIGHWAY COMMERCIAL

PROPOSED SPECIAL PERMIT: SOLAR ENERGY SYSTEM ARRAY (TIER 3)

REQUIREMENTS	REQUIRED	PROVIDE
MINIMUM LOT AREA (SOLAR CODE) (LL 8-2018)	10 AC	28.77 AC
MAXIMUM HEIGHT (SOLAR) (LL 8-2018)25 FT	25 FT	± 6.42 FT
MINIMUM SETBACK (SOLAR IN R-40) (LL 8-2018)		
MINIMUM SETBACK FROM PROPERTY LINE	100 FT / 200 FT*	± 225.4 FT
MINIMUM SETBACK FROM NEAREST HABITABLE STRUCTURE	200 FT	± 803 FT
MINIMUM SETBACK (SOLAR IN HC) (LL 8-2018)	100 FT	± 36.3 FT**
MINIMUM FRONT YARD SETBACK (HC) (307 ATTACHMENT 5)	30 FT	± 36.3 FT
MINIMUM LANDSCAPE COVERAGE (% OF LOT AREA) (LL 8-2018)	SAME AS UNDERLYING ZONE/30%	99.69%

\* APPROVING AUTHORITY MAY VARY SETBACK TO 100 FT OR 200 FT FROM NEAREST HABITABLE BUILDING, WHICHEVER IS MORE RESTRICTIVE.

\*\* PLANNING BOARD REVIEW AND DETERMINATION OF RELIEF REQUIRED

**WETLAND REQUIREMENTS**

TOWN OF CORTLANDT - ZONING DISTRICTS R-40 SINGLE FAMILY AND HC - HIGHWAY COMMERCIAL

PROPOSED SPECIAL PERMIT: CHAPTER 179: SOLAR ENERGY SYSTEM ARRAY (TIER 3)

REQUIREMENTS	REQUIRED	PROVIDE
MINIMUM BUFFER FROM OUTERMOST BOUNDARY OF WETLAND (§179-2.7 WETLAND BUFFER AREA)	100 FT	100 FT

**STEEP SLOPE REQUIREMENTS**

TOWN OF CORTLANDT - ZONING DISTRICTS R-40 SINGLE FAMILY AND HC - HIGHWAY COMMERCIAL

PROPOSED SPECIAL PERMIT: CHAPTER 259: SOLAR ENERGY SYSTEM ARRAY (TIER 3)

REQUIREMENTS	REQUIRED	PROVIDE
MAXIMUM DISTURBANCE ALONG RIDGELINE (§259-6(H)(5))	100 FT WIDTH FOR 100 FT	N/A
MAXIMUM SLOPES WITHOUT STABILIZATION OR RETAINING WALL (§259-6(H)(8))	1 VERTICAL: 2 HORIZONTAL	1 VERTICAL: 2 HORIZONTAL

**TREE CLEARING AND MITIGATION REQUIREMENTS**

TOWN OF CORTLANDT - ZONING DISTRICTS R-40 SINGLE FAMILY AND HC - HIGHWAY COMMERCIAL

PROPOSED SPECIAL PERMIT: CHAPTER 283: SOLAR ENERGY SYSTEM ARRAY (TIER 3)

TREE SAMPLE AREA	DENSITY
0.25 AC	39 TREES
TOTAL TREES PER DISTURBANCE AREA	39/0.25 AC X 3.90 AC = 609 TREES
TOTAL DISTURBANCE AREA	3.90 AC
SLOPES 0-25% AREA	3.30 AC/84.6%
SLOPES 25% OR GREATER AREA	0.60 AC/15.4%

	REQUIRED	PROVIDED
MINIMUM TREE REPLANTING DENSITY (§283-3(C)(3)(D)(1))	1 TREE : 1,000 SF	-

MINIMUM TREE REPLANTING RATIO (§283-3(C)(3)(D)(3))

609 TREES	1.5 (0-25%) x 84.6%:	773 TREES
609 TREES	2.0 (25% OR GREATER) x 15.4%:	188 TREES
TOTAL TREES FOR MITIGATION FUND CALCULATION:		961 TREES

\*\*\* OWNER TO MAKE CONTRIBUTION TO TREE MITIGATION FUND BASED ON TOTAL TREES REQUIRED AND PUBLISHED TOWN TREE VALUE

**LEGEND**

	PROPERTY LINE
	ADJOINING PROPERTY LINE
	EASEMENT LINE
	PROPOSED TOWN EASEMENT
	ZONE BOUNDARY
	INDEX CONTOUR
	CONTOUR
	WETLANDS DELINEATION
	100' WETLANDS BUFFER
	YARD SETBACK
	100' COMMERCIAL SETBACK
	SWALE
	CURB LINE
	EDGE OF CONCRETE
	EDGE OF GRAVEL
	EDGE OF PAVEMENT
	OVERHEAD WIRES
	CHAIN LINK FENCE
	PROPOSED CHAIN LINK FENCE
	GUIDE RAIL
	PAINTED TRAFFIC LINES
	STONE WALL
	TREE LINE
	STRUCTURE
	MONUMENT FOUND
	DRILL HOLE FOUND
	UTILITY POLE
	CATCH BASIN
	MANHOLE (UNKNOWN)
	SIGN
	BOLLARD
	TREE
	BUSH
	WETLANDS FLAG

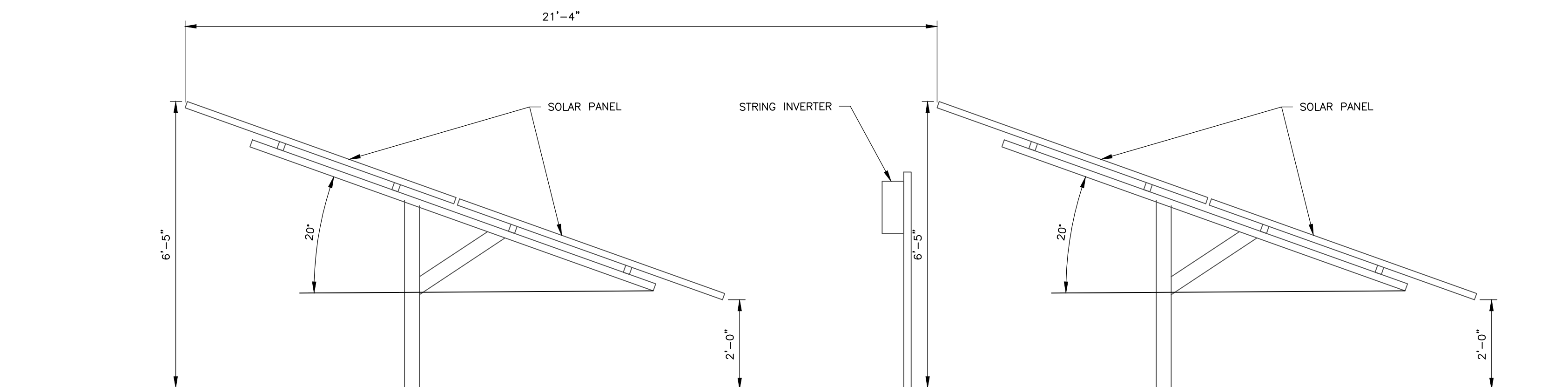

**1 SOLAR ARRAY**  
SK-101 SCALE: 1/2" = 1'-0"

UNAUTHORIZED ALTERATION OR ADDITIONS TO A DOCUMENT BEARING THE SEAL OF A LICENSED PROFESSIONAL ENGINEER OR LAND SURVEYOR IS A VIOLATION OF SECTION 7209 SUBSECTION 2 OF THE NEW YORK STATE EDUCATION LAW.

COPIES OF THIS DOCUMENT WITHOUT A FACSIMILE OF THE SIGNATURE AND AN ORIGINAL EMOSSSED SEAL OR ORIGINAL STAMP OF THE PROFESSIONAL ENGINEER OR LAND SURVEYOR SHALL NOT BE CONSIDERED VALID COPIES.

THIS DOCUMENT IS PREPARED SPECIFICALLY FOR THE CLIENT AND PROJECT DESIGNATED HEREON. MODIFICATION, ALTERATION, REVISION, DUPLICATION, OR USE WITHOUT THE CONSENT OF TECTONIC IS STRICTLY PROHIBITED. COPYRIGHT 2019 TECTONIC. ALL RIGHTS RESERVED.



Rev	Date	Revision	Approved	DRAWING CONTROL			
1	5/29/19	UPDATE RACKING SYSTEM PER CLIENT		Designed by: AMS	Drawn by: ECM	Checked by: LJG	
2	7/10/19	ADDED SCREENING AND EQUIPMENT		Purpose	Released by	Date	
				<input type="radio"/> For Comment			
				<input type="radio"/> For Approval			
				<input type="radio"/> For Bid			
				<input type="radio"/> For Construction			

**Tectonic**  
PRACTICAL SOLUTIONS. EXCEPTIONAL SERVICE.  
Tectonic Engineering & Surveying Consultants P.C.  
70 Pleasant Hill Road Phone: (845) 534-5959  
P.O. Box 37 (800) 829-6531  
Mountainville, NY 10953  
www.tectonicengineering.com

**ADJOINERS LIST, ZONING TABLE, LEGEND & NOTES**

**CVE - CORTLANDT (LEXINGTON)**  
**3262 E. MAIN STREET**  
**TOWN OF CORTLANDT**  
**WESTCHESTER COUNTY, NEW YORK**

Date: 5/9/2019	Work Order	Drawing No.	Rev
Scale: AS NOTED	9489.01	SK-101	2

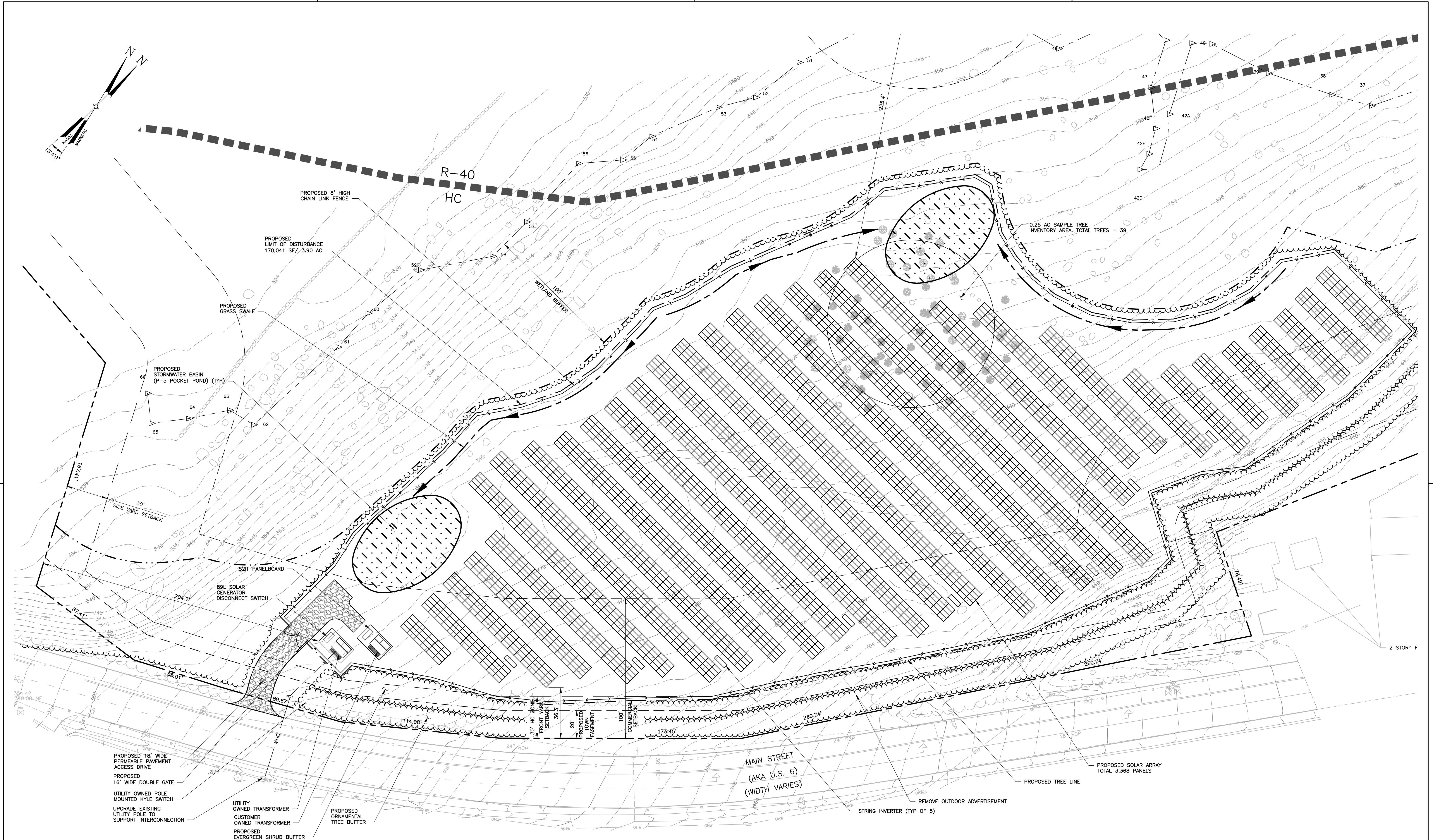

UNAUTHORIZED ALTERATION OR ADDITIONS TO A DOCUMENT BEARING THE SEAL OF A LICENSED PROFESSIONAL ENGINEER OR LAND SURVEYOR IS A VIOLATION OF SECTION 7209 SUBSECTION 2 OF THE NEW YORK STATE EDUCATION LAW.

COPIES OF THIS DOCUMENT WITHOUT A FACSIMILE OF THE SIGNATURE AND AN ORIGINAL EMBOSSED SEAL OR ORIGINAL STAMP OF THE PROFESSIONAL ENGINEER OR LAND SURVEYOR SHALL NOT BE CONSIDERED VALID COPIES.

THIS DOCUMENT IS PREPARED SPECIFICALLY FOR THE CLIENT AND PROJECT DESIGNATED HEREON. MODIFICATION, ALTERATION, REVISION, DUPLICATION, OR USE WITHOUT THE CONSENT OF TECTONIC IS STRICTLY PROHIBITED. COPYRIGHT 2019 TECTONIC. ALL RIGHTS RESERVED.

0 1 2 3  
ORIGINAL SIZE IN INCHES

Rev	Date	Revision	Approved
1	5/29/19	UPDATE RACKING SYSTEM PER CLIENT	
2	7/10/19	ADDED SCREENING AND EQUIPMENT	

DRAWING CONTROL			
Designed by:	AMS	Drawn by:	ECM
Checked by:	LIG	Released by:	Date
<input type="radio"/>	For Comment		
<input type="radio"/>	For Approval		
<input type="radio"/>	For Bid		
<input type="radio"/>	For Construction		

**Tectonic**  
PRACTICAL SOLUTIONS. EXCEPTIONAL SERVICE.

Tectonic Engineering & Surveying Consultants P.C.  
70 Pleasant Hill Road P.O. Box 37  
Mountainville, NY 10953  
Phone: (845) 534-5959 (800) 829-6531  
www.tectonicengineering.com

ADVANCED CONCEPT PLAN

CVE - CORTLANDT (LEXINGTON)  
3262 E. MAIN STREET  
TOWN OF CORTLANDT  
WESTCHESTER COUNTY, NEW YORK

Date	8/9/2019	Work Order	9489.01	Drawing No.	SK-102	Rev	2
Scale	1" = 30'						



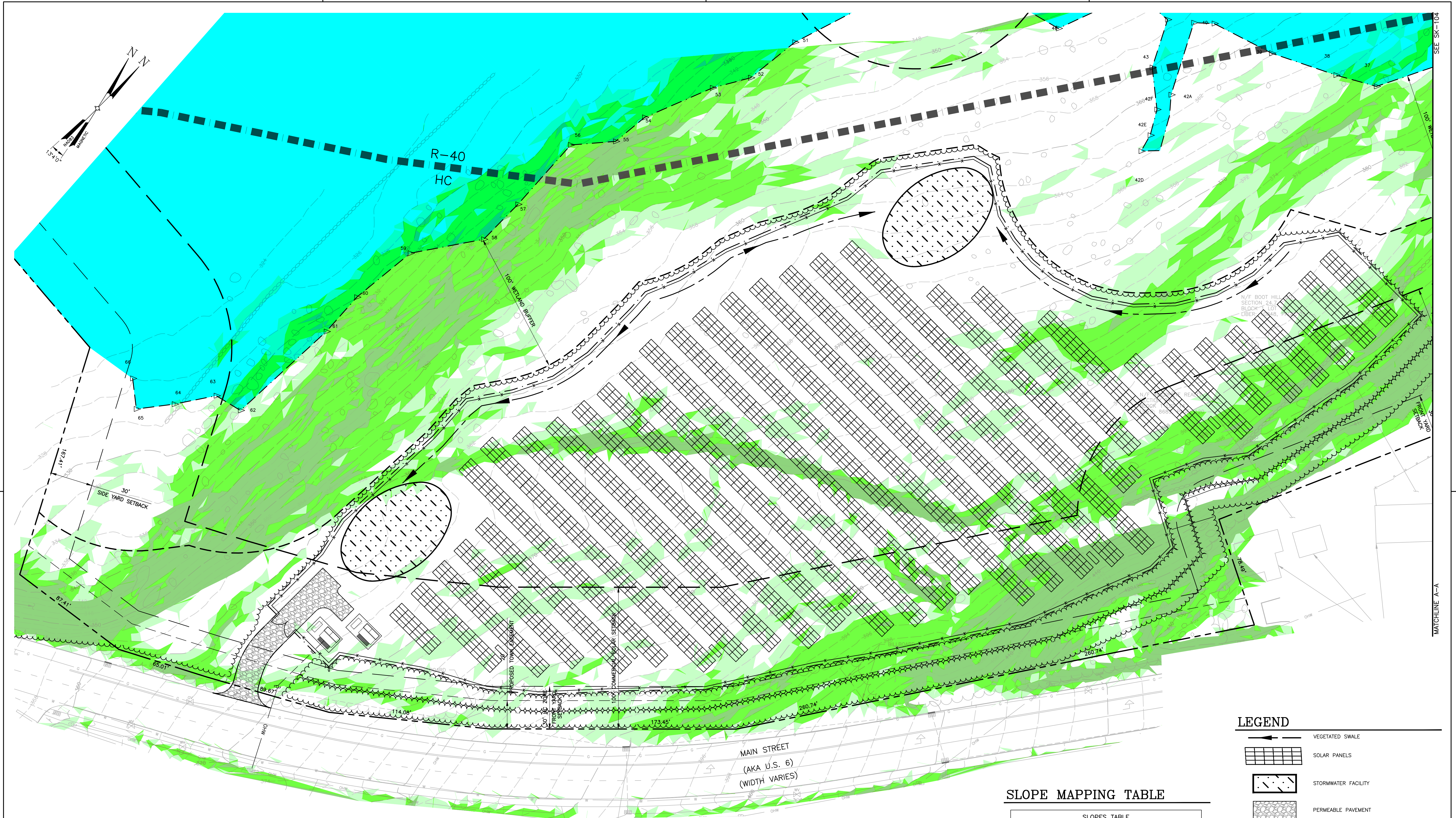

**LEGEND**

- VEGETATED SWALE
- SOLAR PANELS
- STORMWATER FACILITY
- PERMEABLE PAVEMENT
- EQUIPMENT
- FENCE
- LIMIT OF DISTURBANCE

**SLOPE MAPPING TABLE**

SLOPES TABLE			
NUMBER	MINIMUM SLOPE	MAXIMUM SLOPE	COLOR
1	15.00%	20.00%	
2	20.00%	30.00%	
3	30.00%	100.00%	

UNAUTHORIZED ALTERATION OR ADDITIONS TO A DOCUMENT BEARING THE SEAL OF A LICENSED PROFESSIONAL ENGINEER OR LAND SURVEYOR IS A VIOLATION OF SECTION 7209 SUBSECTION 2 OF THE NEW YORK STATE EDUCATION LAW.

COPIES OF THIS DOCUMENT WITHOUT A FACSIMILE OF THE SIGNATURE AND AN ORIGINAL EMBOSSED SEAL OR ORIGINAL STAMP OF THE PROFESSIONAL ENGINEER OR LAND SURVEYOR SHALL NOT BE CONSIDERED VALID COPIES.

THIS DOCUMENT IS PREPARED SPECIFICALLY FOR THE CLIENT AND PROJECT DESIGNATED HEREON. MODIFICATION, ALTERATION, REVISION, DUPLICATION, OR USE WITHOUT THE CONSENT OF TECTONIC IS STRICTLY PROHIBITED. COPYRIGHT 2019 TECTONIC. ALL RIGHTS RESERVED.

0 1 2 3  
ORIGINAL SIZE IN INCHES

Rev	Date	Revision	Approved	DRAWING CONTROL			
1	5/29/19	UPDATE RACKING SYSTEM PER CLIENT		Designed by: AMS	Drawn by: ECM	Checked by: LIG	
2	7/10/19	ADDED SCREENING AND EQUIPMENT		Released by: _____ Date: _____			

**Tectonic**  
PRACTICAL SOLUTIONS. EXCEPTIONAL SERVICE.

Tectonic Engineering & Surveying Consultants P.C.  
70 Pleasant Hill Road  
Mountainville, NY 10953  
www.tectonicengineering.com

Phone: (845) 534-5959  
(800) 829-6531

**WETLANDS & STEEP SLOPES MAP**

CVE - CORTLANDT (LEXINGTON)  
3262 E. MAIN STREET  
TOWN OF CORDLANDT  
WESTCHESTER COUNTY, NEW YORK

Date: 8/9/2019	Work Order: 9489.01	Drawing No.: SK-103	Rev: 2
----------------	---------------------	---------------------	--------

Scale: 1" = 30'



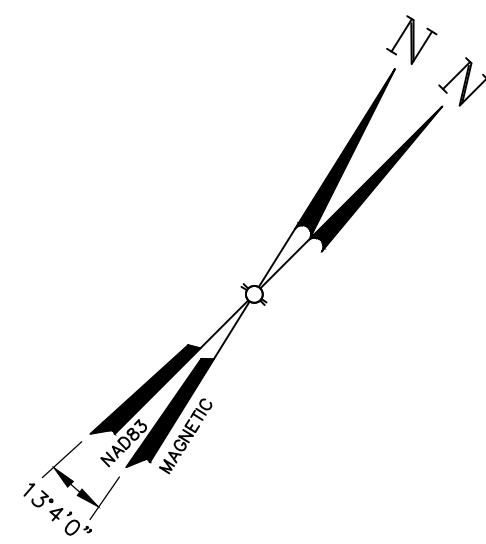

SEE SK-103

MATCHLINE A-A

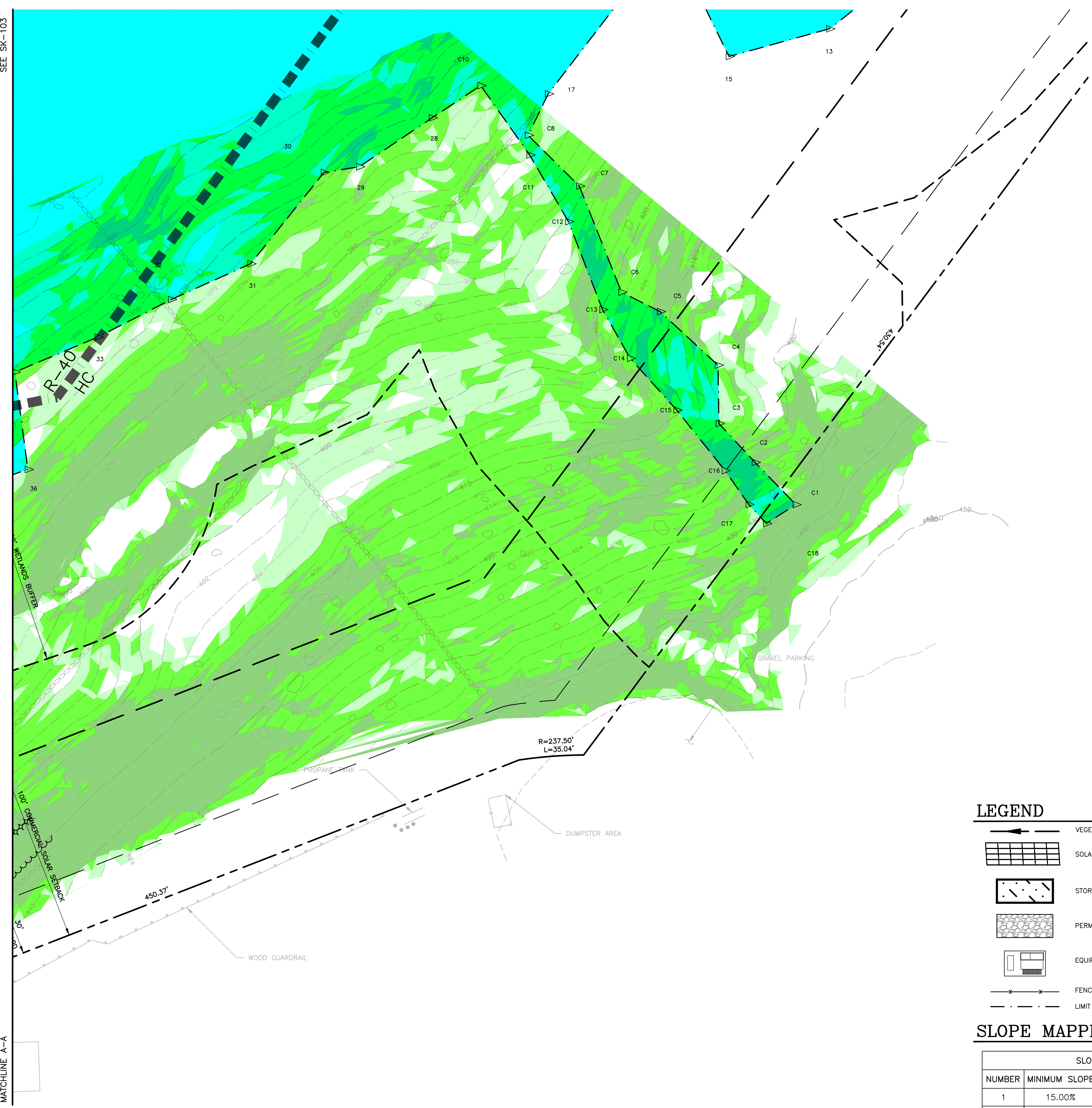

**LEGEND**

- VEGETATED SWALE
- SOLAR PANELS
- STORMWATER FACILITY
- PERMEABLE PAVEMENT
- EQUIPMENT
- FENCE
- LIMIT OF DISTURBANCE

**SLOPE MAPPING TABLE**

SLOPES TABLE			
NUMBER	MINIMUM SLOPE	MAXIMUM SLOPE	COLOR
1	15.00%	20.00%	
2	20.00%	30.00%	
3	30.00%	100.00%	

UNAUTHORIZED ALTERATION OR ADDITIONS TO A DOCUMENT BEARING THE SEAL OF A LICENSED PROFESSIONAL ENGINEER OR LAND SURVEYOR IS A VIOLATION OF SECTION 7209 SUBSECTION 2 OF THE NEW YORK STATE EDUCATION LAW.

COPIES OF THIS DOCUMENT WITHOUT A FACSIMILE OF THE SIGNATURE AND AN ORIGINAL EMBOSSED SEAL OR ORIGINAL STAMP OF THE PROFESSIONAL ENGINEER OR LAND SURVEYOR SHALL NOT BE CONSIDERED VALID COPIES.

THIS DOCUMENT IS PREPARED SPECIFICALLY FOR THE CLIENT AND PROJECT DESIGNATED HEREON. MODIFICATION, ALTERATION, REVISION, DUPLICATION, OR USE WITHOUT THE CONSENT OF TECTONIC IS STRICTLY PROHIBITED. COPYRIGHT 2019 TECTONIC. ALL RIGHTS RESERVED.

ORIGINAL SIZE IN INCHES

Rev	Date	Revision	Approved	DRAWING CONTROL			
				Designed by:	Drawn by:	Checked by:	LIG
1	5/29/19	UPDATE RACKING SYSTEM PER CLIENT		AMS	ECM		LIG
2	7/10/19	ADDED SCREENING AND EQUIPMENT					

Purpose:

- For Comment
- For Approval
- For Bid
- For Construction

**Tectonic**  
 PRACTICAL SOLUTIONS. EXCEPTIONAL SERVICE.  
 Tectonic Engineering & Surveying Consultants P.C.  
 70 Pleasant Hill Road Phone: (845) 534-5959  
 P.O. Box 37 Mountainville, NY 10953 (800) 829-6531  
[www.tectonicengineering.com](http://www.tectonicengineering.com)

**WETLANDS & STEEP SLOPES MAP**

**CVE - CORTLANDT (LEXINGTON)**  
 3262 E. MAIN STREET  
 TOWN OF CORDLANDT  
 WESTCHESTER COUNTY, NEW YORK

Date: 8/9/2019	Work Order: 9489.01	Drawing No.: SK-104	Rev: 2
----------------	---------------------	---------------------	--------